

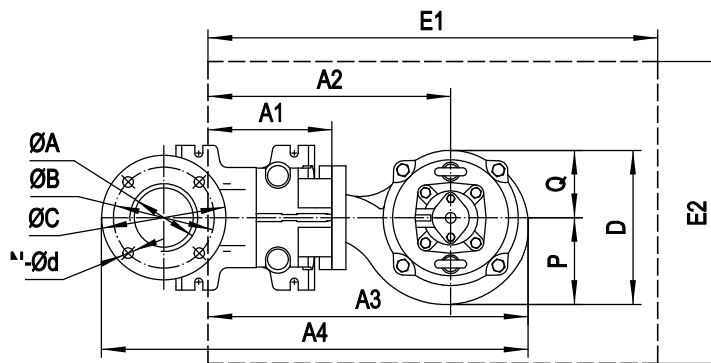

Stopa sprzęgająca do WQ | VX

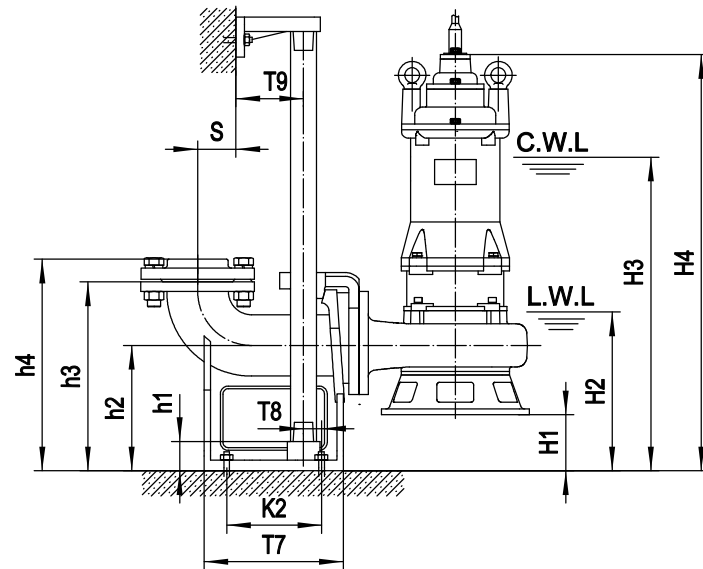
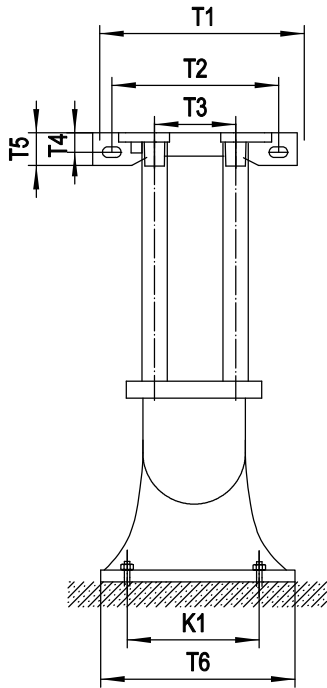

Stopa sprzęgająca pasuje do:
WQ 65-4,0 | WQ 80-3,0
VX 80-1,5 | VX 80-2,2

Model	Stopa sprzęgająca	H1	H2	H3	H4	A1	A2	A3	A4	P	Q	D	E1 / E2	N.W.
WQ 80-3	DN80 PN6	68	235	515	695	176	329	436	608	115	100	215	650 / 550	50
WQ 65-4	DN65 PN6	45	205	500	695	155	333	448	619	115	115	230	650 / 550	58
VX 80-1,5	DN80 PN6	80	250	480	645	176	340	447	620	110	107	217	650 / 550	39
VX 80-2,2	DN80 PN6	80	250	500	665	176	340	447	620	110	107	217	650 / 550	41